

Model INV-100 Product Overview

CHP Basics

Combined Heat and Power (CHP) is the well-known process of siting electrical power generation machinery within facilities that have a significant heating requirement. The generator is heavily utilized to supplement the electrical power needs of the facility, while the low-grade heat, normally discarded in large power plant operation, is recovered and purposefully used in the facility. The benefit to customers is a dramatic reduction in their energy costs, while the societal benefit, relative to greenhouse gas reductions, is likewise impressive; with CHP efficiency typically twice that of conventional utility power, carbon emissions are inversely proportional, i.e., reduced by 50% or more.

CHP is recommended by many notable environmental groups, such as the Sierra Club, Greenpeace, and the America Council for Energy Efficient Economy as a preferred resource option for the future.

Tecogen INV-100 – The Next Generation CHP Technology

The Tecogen INV-100, shown in Figure 1, is natural gas fueled Combined Heat and Power (CHP) module rated at 100 kW continuous electrical output while simultaneously producing 7.3 therms per hour of hot water (230°F). Its overall efficiency is 92%, when all the recoverable heat is used.

The INV-100 utilizes a totally unique power generation technology made possible from recent advances and cost breakthroughs in power electronics (variable speed drives) and magnetic motor/generator materials (hybrid vehicle drive systems). The product was developed under a major grant from the California Energy Commission's Public Interest Energy Research (PIER) program and Sempra Utilities (Southern California Gas/San Diego Gas & Electric).

The InVerde Module, conceptually depicted in Figure 2, features a low-emissions natural gas engine, which drives a water-cooled permanent magnetic generator (PMG). The engine is operated over a wide speed range, depending on the load requirement, while the power electronics convert the variable frequency output from the PMG to high quality 60-Hertz power. Variable speed operation in grid-tie mode maximizes fuel



Figure 1. Tecogen InVerde Module Model INV-100

efficiency under part load conditions, while also allowing operation in a "peaking" mode of 125 kilowatts for several hundred hours per year to offset especially high "on-peak" utility demand tariffs and energy charges or to obtain extra savings from utility demand reduction programs.

This is the first engine-driven product to carry full UL 1741 Certification for "utility-safe" interconnection, while also providing seamless power transfer to stand-alone operation in the event of a power outage. The product features the proprietary control software, incorporated under exclusive license from the Wisconsin Alumni Research Foundation and demonstrated at the AEP Dolan Laboratory, enabling multiple machines to load-share on an isolated bus, without any interconnecting or supervisory controls.

The highly innovative control method solves the heretofore-intractable problem of applying clusters of small-scale prepackaged CHP modules that can operate both in grid-tie mode and during power outages, without complex and expensive controls. The single InVerde Module, equipped with this control architecture, can be applied in a building block fashion to many types and sizes of facilities, and provide power outage security, in addition to their CHP benefits.

¹ Based on the lower heating value (LHV) of natural gas (905 BTU/ft³)

² The Wisconsin Alumni Research Foundation is the University of Wisconsin's technology licensing affiliate.

³ AEP is American Electric Power, the 11-state Midwest Electric Utility.

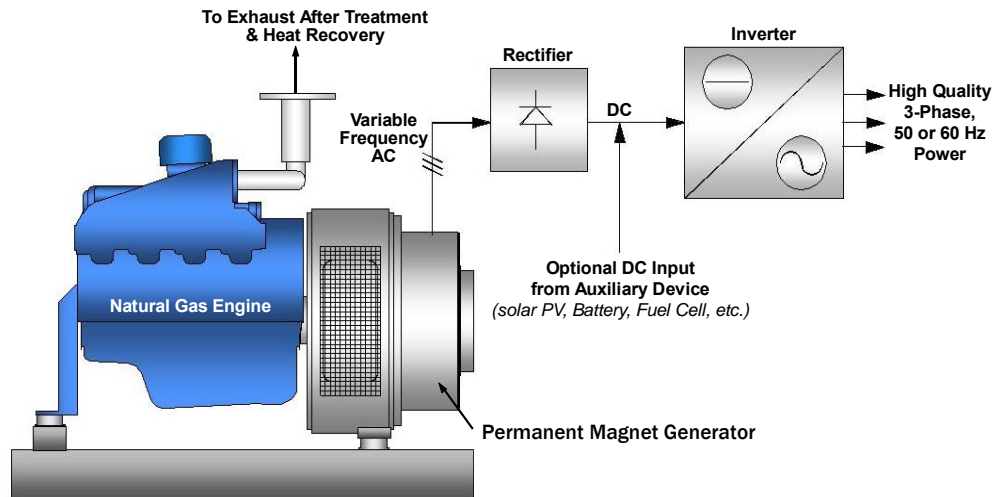

Figure 2 – The INV-100 Advanced Power Generation Technology

Electrical Configuration for Dual Purpose (Grid Tie and Back-up Power)

A simplified schematic of a multiple-unit installation is shown in Figure 3a. The three modules share a common circuit that contains a group of loads. As the total power requirements of the building would generally exceed the capability of the three modules, power to the loads is supplemented by the utility. Upon failure of the grid (Figure 3b) the main circuit breaker that feeds the facility is opened while the units are placed in idle (no power mode). Loads considered less important are shed to bring the total power requirement within the

capability of the three modules (i.e., 300 kW or less). Upon confirmation that the loads have been shed and the breaker opened to isolate the system, the units resume powering the interconnected loads until utility power is restored.

This power changeover process can be fully automated or, in the most basic configuration, done manually. In either case, the process is simple and the system designer need only manage a sequence of events. The proprietary control software automatically balances and synchronizes the three modules.

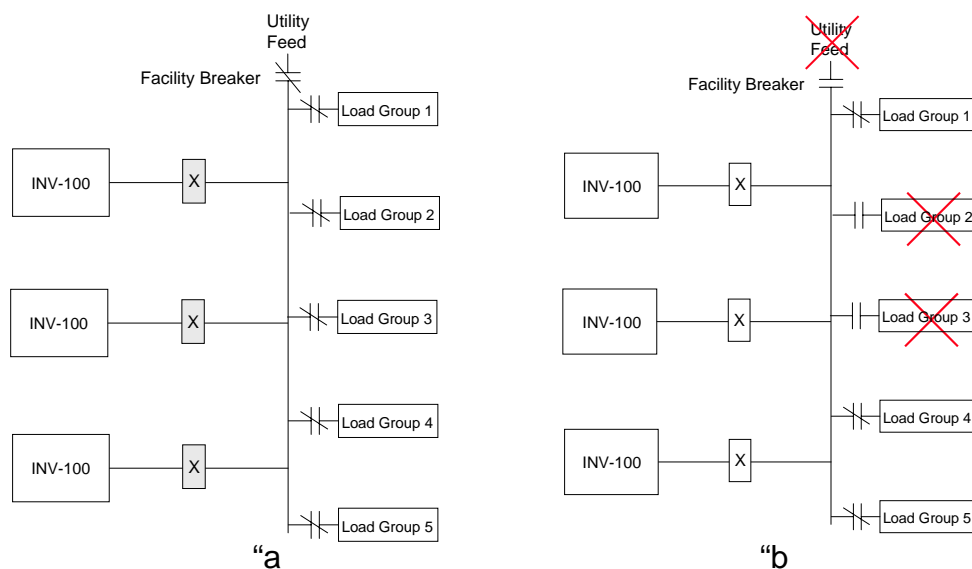

Figure 3a and 3b - Conceptual electrical configuration of a facility with multiple INV-100 Modules. In normal grid-tie "a", loads are powered by modules and utility. After outage ("b") utility feed is isolated, less critical

Solar Photo-voltaic (PV) Integration

Solar PV systems can be integrated electrically with the INV-100 in two ways. The first method would be to add the PV's AC output to the common load center as another power source feeding the circuit. Alternatively, the DC output from the PV system may be injected directly into the DC bus of the INV-100 (see Figure 2). In this case, the INV-100 will automatically reduce engine power to offset the added kW injected into the bus. For example, if the setpoint of the unit were 100 kW and the PV injection were 10 kW, then engine power would reduce to the equivalent of 90 kW.

Typical Applications

The most common applications for the product are facilities that have concurrent and consistent electric and heating loads and ownership that values the standby power feature. Typical applications are schools, hospitals, recreation facilities, and multi-unit housing of almost any category (e.g., elder housing, condominiums, nursing care homes, dormitories, etc.).

Obtaining More Information

For more information about the INV-100 Premium Power Module contact Mr. William Martini, Tecogen West Coast Sales Manager at 503 641 1768, or Mr. Jeffery Glick, the Tecogen East Coast Sales Manager at 781 466 6481. Detailed specifications are available at www.tecogen.com.